

### 1. CAUTIONARY NOTES FOR SAFE USE OF THE PRODUCT

This user's manual should be carefully read before installing and operating the product. The following symbol is used on the product and in this manual to ensure safe use.



**This symbol is displayed on the product when it is necessary to refer to the user's manual for information on personnel and instrument safety. This symbol is displayed in the user's manual to indicate precautions for avoiding danger to the operator, such as an electric shock.**

The following symbols are used only in this manual.



#### IMPORTANT

**Indicates that operating the hardware or software in a particular manner may cause damage or result in a system failure.**



#### NOTE

**Draws attention to essential information for understanding the operations and/or functions of the product.**

### 2. CHECKING THE PRODUCT SPECIFICATIONS AND THE CONTENTS OF THE PACKAGE

#### (1) Model and Specifications Check

Check that the model and specifications indicated on the nameplate attached to the side face of the main unit are as ordered.

#### (2) Contents of the Package

Check that the package contains the following items:

- VJAK: 1
- User's manual (this manual: IM 77J01A21-01E): 1

#### Accessories:

- Tag number label: 1 sheet

### 3. GENERAL

This plug-in type Limit Alarm for DC current input receives 4 to 20 mA DC current signal. It is used in combination with two-wire type transmitter.

- Each parameter setting can be changed using a PC (VJ77 PC-based Parameters Setting Tool) or the Handy Terminal (JHT200).

### 4. MODEL AND SUFFIX CODES

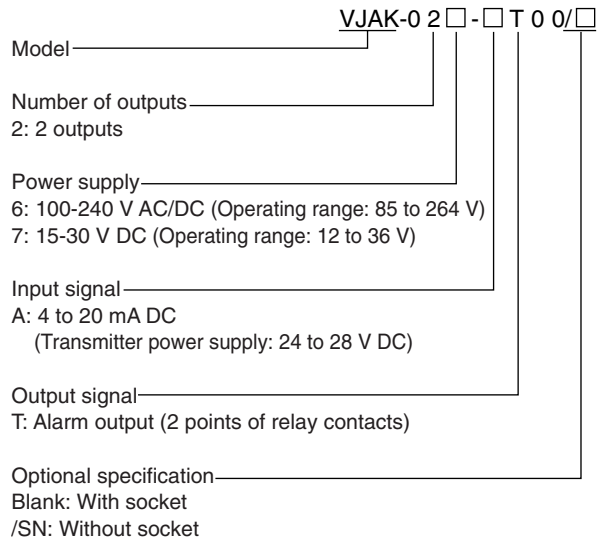

### 5. MOUNTING METHODS

#### 5.1 Wall Mounting

Loosen the main unit-fixing screw to disconnect the main unit from the socket. Next, anchor the socket onto the wall with screws. Then, plug the main unit into the socket and secure the main unit with the main unit-fixing screw.

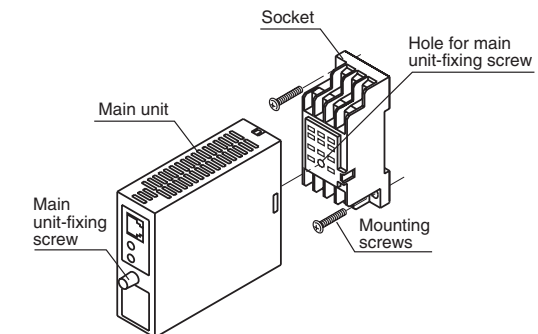

<Mounting Dimensions>

Unit: mm

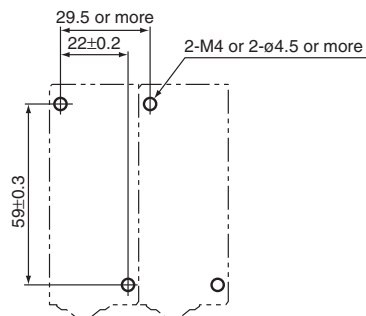

Fig.5.1

Keep this manual in a safe place.

## 5.2 DIN Rail Mounting

Locate the VJAK so that the DIN rail fits into the upper part of the DIN-rail groove at the rear of the socket, and fasten the socket using the slide lock at the lower part of the socket.

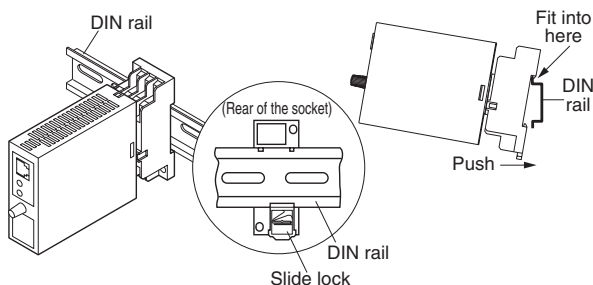

Fig. 5.2

## 5.3 Using a Duct

Wiring duct should be installed at least 30 mm away from the top and bottom faces of the main unit.

## 6. INSTALLATION LOCATIONS

- Avoid the following environments for installation locations: Areas with vibrations, corrosive gases, dust, water, oil, solvents, direct sunlight, radiation, a strong electric field, and/or a strong magnetic field.
- If there is any risk of a surge being induced into the power line and/or signal lines due to lightning or other factors, a dedicated lightning arrester should be used as protection for both the product and a field-installed device.

## 7. EXTERNAL WIRING



### WARNING

**To avoid the risk of an electric shock, turn off the power supply and use a tester or similar device to ensure that no power is supplied to a cable to be connected, before carrying out wiring work.**

Wiring should be connected to the terminals on the socket of the VJAK. The terminals for external connections are of M3 screws. Use crimp-on lugs for connections to the terminals.

- It is recommended that signal wires have a nominal cross-sectional area of 0.5 mm<sup>2</sup> or thicker, while the power cable has a nominal cross-sectional area of 1.25 mm<sup>2</sup> or thicker.

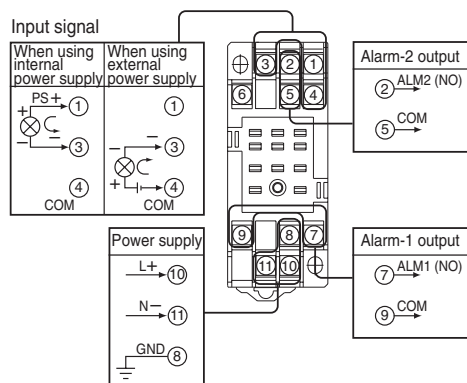

When connecting the transmitter to the VJAK directly without using the transmitter power supply, connect [+] of the transmitter output to the terminal no. 3 and connect [-] to the terminal no. 4.



### IMPORTANT

- **Use of the product ignoring the specifications may cause overheating or damage. Before turning on the power, ensure the following:**
  - (a) Power supply voltage and input signal value applied to the product should meet the required specifications.
  - (b) The external wiring to the terminals and wiring to ground are as specifications.
- Do not operate the product in the presence of flammable or explosive gases or vapors. To do so is highly dangerous.
- The product is sensitive to static electricity; exercise care in operating it. Before you operate the product, touch a nearby metal part to discharge static electricity.
- If an inductance (L) load such as auxiliary relays or solenoid valves is used, always insert a spark killer for diminishing sparks, such as a CR filter or a diode in parallel with the inductance load. Otherwise a malfunction or relay failure may occur. Refer to the following guidelines for a capacitor and resistor:  
Capacitor : 0.5 to 1  $\mu$ F with respect to a contact current of 1 A  
Resistor: 0.5 to 1  $\Omega$  with respect to a contact voltage of 1 V
- The power line and input/output signal lines should be installed away from noise-generating sources. Otherwise accuracy cannot be guaranteed.
- The grounding resistance must be 100  $\Omega$  (JIS Class D grounding). The length and thickness of the grounding cable should be as short and thick as possible. Directly connect the lead from the ground terminal (terminal no. 8) of the product to the ground. Do not carry out daisy-chained inter-ground terminal wiring.

## 8. DESCRIPTION OF FRONT PANEL AND CONNECTION OF SETTING TOOLS

### 8.1 Front Panel

The communications connector on the front panel is used for setting up parameters using a PC (VJ77 PC-based Parameters Setting Tool) or the Handy Terminal (JHT200). The alarm indicator lamps for alarm 1 and alarm 2 light up if an alarm occurs.

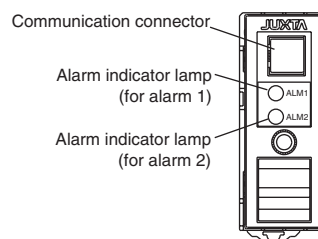

Fig. 8.1 Front Panel

## 8.2 Connecting the Setting Tools

Connect the modular jack conversion adapter (E9786WH) to the JUXTA communication cable with 5-pin connector (F9182EE) and then connect this adapter to the communication connector of JUXTA.

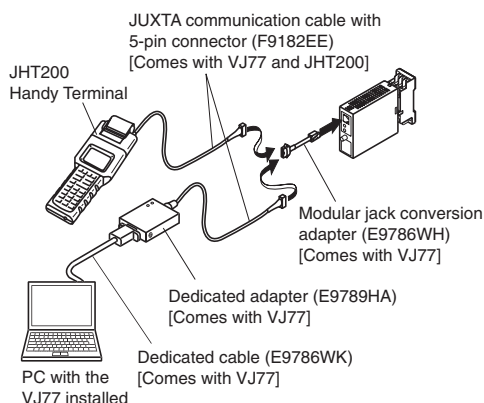

Fig. 8.2 Connecting the Setting Tools

Note: The modular jack conversion adapter does not come with the JHT200 Handy Terminal. It is sold separately.

## 9. SETTING PARAMETERS

Set the parameters using a PC (VJ77 PC-based Parameters Setting Tool) or the Handy Terminal (JHT200). Refer to the list of parameters in this manual and the user's manual for VJ77 PC-based Parameters Setting Tool (IM 77J01J77-01E) or JHT200 Handy Terminal (IM JF81-02E).

### 9.1 Settings Related to Input

#### 9.1.1 Square Root Extraction Function

Select SQR in D11: LINEARIZE to set "with square root extraction function."

#### 9.1.2 Low-cut Function

Set the low-cut point in D12: LOW CUT numerically when "with square root extraction function" is set.

- Setting range: 0 to 100% of input range
- Setting resolution: 0.1%

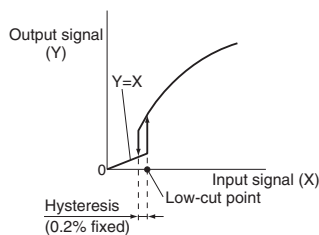

### 9.2 Settings Related to Alarm Output

#### 9.2.1 Alarm Setpoint

Set the alarm setpoints of alarm 1 and alarm 2 in E03: SET POINT1 and E04: SET POINT2 numerically.

- Setting range: 0 to 100% of input range
- Setting resolution: 0.1%

#### 9.2.2 Direction of Alarm Action

Select the direction of alarm-1 action and that of alarm-2 action from among HIGH ALM (high-limit alarm) and LOW ALM (low-limit alarm) in E05: ALM1 ACTION and E06: ALM2 ACTION.

- To activate alarm status when input signal  $\geq$  alarm setpoint, select HIGH ALM.
- To activate alarm status when input signal  $\leq$  alarm setpoint, select LOW ALM.

#### 9.2.3 Hysteresis

Set the alarm-1 and alarm-2 hysteresis in E09: HYSTERESIS1 and E10: HYSTERESIS2. Hysteresis is a value added to the alarm setpoint in order for an alarm status to be released (to normal) after the alarm status has been activated. The alarm status will be released in the following conditions, depending on the direction of alarm action.

- \* When HIGH ALM (high-limit alarm) is set: Alarm is released when input signal  $<$  (alarm setpoint - hysteresis).
- \* When LOW ALM (low-limit alarm) is set: Alarm is released when input signal  $>$  (alarm setpoint + hysteresis).
- Setting range: 0 to 100% of input range
- Setting resolution: 0.1%

#### 9.2.4 Alarm ON Delay and Alarm OFF Delay

Set the alarm-1 and alarm-2 ON delays in E11: ON DELAY1 and E12: ON DELAY2 and then alarm-1 and alarm-2 OFF delays in E13: OFF DELAY1 and E14: OFF DELAY2.

An alarm ON delay is the condition monitoring time from the establishment of alarm conditions to its output; an alarm OFF delay is the condition monitoring time from the establishment of return-to-normal conditions to its output.

- Setting range: 0 to 999 seconds
- Setting resolution: 1 second (However, about 0.2 second is to be added to the set time to prevent wrong operation.)

For example, when an alarm ON delay is set to 1 second, alarm output is generated if alarm status continues for 1 second or more after the input value exceeds the alarm setpoint. Further, when an alarm OFF delay is set to 2 seconds, alarm output is released if normal condition continues for 2 seconds or more after the input value has returned to normal from the alarm status.

#### 9.2.5 Direction of Relay Action

Select the direction of relay energizing in alarm-1 normal condition and alarm-2 normal condition from among NRM DE-ENERGIZED (de-energized under normal condition) and NRM ENERGIZED (energized under normal condition) in E15: RL1 ACTION and E16: RL2 ACTION.

## 10. DESCRIPTION OF ALARM ACTIONS

This chapter describes examples of alarm actions under the following conditions.

Item	Alarm 1		Alarm 2	
	Parameter	Setpoint	Parameter	Setpoint
Direction of alarm action	E05 : ALM1 ACTION	High-limit alarm	E06 : ALM2 ACTION	Low-limit alarm
Alarm setting	E03 : SET POINT1	80%	E04 : SET POINT2	15%
Hysteresis	E09 : HYSTERESIS1	10%	E10 : HYSTERESIS2	5%
Alarm ON delay	E11 : ON DELAY1	1 sec	E12 : ON DELAY2	3 sec
Alarm OFF delay	E13 : OFF DELAY1	2 sec	E14 : OFF DELAY2	4 sec
Description of alarm actions	The alarm is output if the condition where the input value is 80% or more of high-limit alarm continues for 1 second or more. After the alarm is output, when the condition where the input value is less than 70% of high-limit alarm continues for 2 seconds or more, the status returns to normal.		The alarm is output if the condition where the input value is 15% or less of low-limit alarm continues for 3 seconds or more. After the alarm is output, when the condition where the input value is more than 20% of low-limit alarm continues for 4 seconds or more, the status returns to normal.	

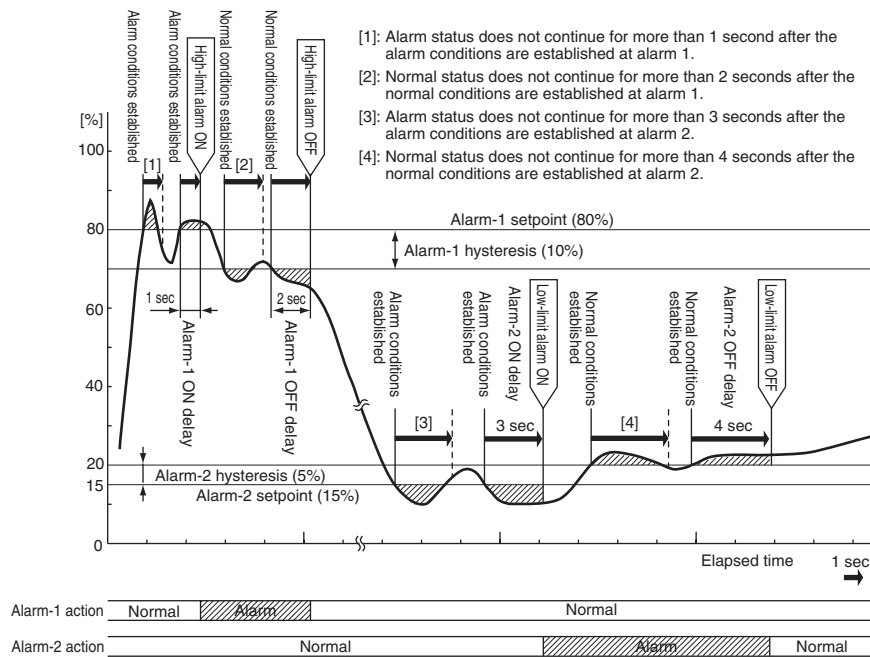

## 11. LIST OF PARAMETERS

No.	Item	Display	No.	Item	Display
01	Model	MODEL			
02	Tag No.	TAG NO			
03	Self-check result	SELF CHK			
<b>Display items</b>					
<b>A</b>	<b>Display 1</b>	<b>DISPLAY1</b>	<b>B</b>	<b>Display 2</b>	<b>DISPLAY2</b>
A01	Input value	INPUT1	B01	Input value	INPUT1
A05	Output value 1	OUTPUT1 (*1)	B05	Output value 1	OUTPUT1 (*1)
A07	Alarm-1 status	ALM1 STATUS	B07	Alarm-1 status	ALM1 STATUS
A08	Alarm-2 status	ALM2 STATUS	B08	Alarm-2 status	ALM2 STATUS
A54	Status	STATUS (*2)	B60	Self-check result	SELF CHK
A56	Rev No.	REV NO			
A58	Menu Rev	MENU REV			
A60	Self-check result	SELF CHK			
<b>Setting items (*3)</b>					
<b>D</b>	<b>Setting (I/O)</b>	<b>SET(I/O)</b>	<b>E</b>	<b>Setting (alarm output)</b>	<b>SET(ALM)</b>
D01	Tag no.1	TAG NO.1	E03	Alarm-1 setting	SET POINT1
D02	Tag no.2	TAG NO.2	E04	Alarm-2 setting	SET POINT2
D03	Comment 1	COMMENT1	E05	Direction of alarm-1 action	ALM1 ACTION
D04	Comment 2	COMMENT2	E06	Direction of alarm-2 action	ALM2 ACTION
D11	Linearize	LINEARIZE	E09	Alarm-1 hysteresis	HYSTERESIS1
D12	Low cut	LOW CUT	E10	Alarm-2 hysteresis	HYSTERESIS2
D38	Direction of output-1 action	OUT1 DR (*1)	E11	Alarm-1 ON delay setting	ON DELAY1
D60	Self-check result	SELF CHK	E12	Alarm-2 ON delay setting	ON DELAY2
			E13	Alarm-1 OFF delay setting	OFF DELAY1
			E14	Alarm-2 OFF delay setting	OFF DELAY2
			E15	Direction of alarm-1 relay action	RL1 ACTION
			E16	Direction of alarm-2 relay action	RL2 ACTION
			E60	Self-check result	SELF CHK
<b>Adjusting items (*3)</b>			<b>Test items (*3)</b>		
<b>P</b>	<b>Adjustment</b>	<b>ADJUST1</b>	<b>Q</b>	<b>Test</b>	<b>TEST</b>
P02	Zero adjustment of input 1	ZERO ADJ1	Q02	Forced output 1	OUT1 TEST (*1)
P03	Span adjustment of input 1	SPAN ADJ1	Q04	Forced output (alarm 1)	ALM1 TEST
P12	0% adjustment of output 1	OUT1 0% (*1)	Q05	Forced output (alarm 2)	ALM2 TEST
P13	100% adjustment of output 1	OUT1 100% (*1)	Q60	Self-check result	SELF CHK
P60	Self-check result	SELF CHK			

\*1 : The indications and settings of the parameters are not available.

\*2 : The status is displayed for service personnel to see history records.

\*3 : To call the parameter setting items D, E, P and Q using the JHT200 Handy Terminal, execute the following operation:

Press  →  →  keys.

D, E, P or Q key enters  above.



### IMPORTANT

**Do not change the settings of the items marked “(\*1)” in the List of Parameters above after the delivery of the product. Doing so may result in a malfunction or a system failure.**

## 12. MAINTENANCE

The product enters the operable status as soon as the power is turned on, but requires 10 to 15 minutes of warm-up to meet the performance requirements.

### 12.1 Calibration Apparatus

- Calibrator (Yokogawa Meters & Instruments' CA71 or equivalent): 1
- Setting tool for adjustment (Refer to "8.2 Connecting the Setting Tools" in this manual.)

### 12.2 Calibration Procedure

- (1) Connect the instruments as shown in Fig.12.1 and Fig. 8.2.
- (2) Produce the input signal equivalent to 0% of the input range from the calibrator to the product. Then, read the input value of Display items, "A01: INPUT1" using the VJ77 or JHT200 and check that the input value is within the rated accuracy range. Take the same procedure for the input signal equivalent to 25, 50, 75 and 100% of the input range and check that the input values are within the rated accuracy range.

For alarm output, check the relay action by the alarm indicator lamp or resistance of output terminals.

If the input values are out of the rated accuracy range, adjust the input signal level referring to the user's manual for VJ77 PC-based Parameters Setting Tool (IM 77J01J77-01E) or for JHT200 Handy Terminal (IM JF81-02E).

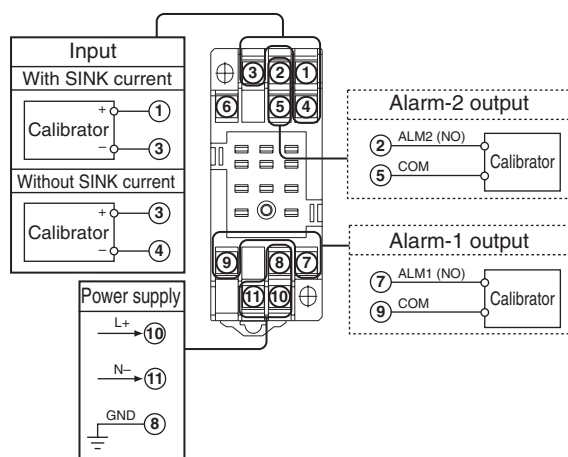

Fig. 12.1